

WITH THE POWER OF LIGHT,
YOU CAN CREATE COLOR

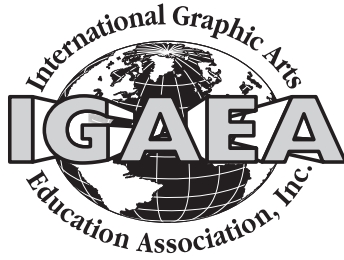

Visual Communications Journal
Spring 2009



Visual Communications JOURNAL

SPRING 2009

Acknowledgements

Editor

Jerry J. Waite, University of Houston

Editorial Review Board

Cynthia Carlton-Thompson, North Carolina A&T State University
James Tenorio, University of Wisconsin–Stout
Zeke Prust, Arizona State University (emeritus)
Bob Chung, Rochester Institute of Technology
Christopher Lantz, Western Illinois University
Malcolm Keif, California Polytechnic State University
Mark Snyder, Millersville University

Cover Design

Jacob Stoltzfus, Thaddeus Stevens College of Technology
Instructor: Dennis Dougherty

Page Design and Layout

Graphic Communications Technology Program, University of Houston

Printing, Bindery, and Distribution

Harold Halliday, University of Houston
University of Houston Printing and Postal Services

About the Journal

The *Visual Communications Journal* serves as the official journal of the International Graphic Arts Education Association, Inc., and provides a professional communicative link for educators and industry personnel associated with design, presentation, management, and reproduction of graphic forms of communication. Manuscripts submitted for publication are subject to peer review by the Association and the views and opinions expressed herein are those of authors and do not necessarily reflect the policy or the views of the IGAEA.

Article Submission

Please follow the guidelines provided at the back of this *Journal*.

Membership and Subscription Information

Information about membership in the Association or subscription to the *Journal* should be directed to the IGAEA Second Vice-President.

President

A. Thomas Loch

Adlai E. Stevenson HS District 125
One Stevenson Drive, Lincolnshire IL 60069
School (847) 634-4000 x1211
tomloch@mac.com

President- Elect

Shaun Dudek

Graphic Arts Technology
College of DuPage
425 Fawell Blvd.
Glen Ellyn, IL 60137-6599
School (630)942-2040
dudeks@cod.edu

First Vice-President (Publications)

Pam Daniel

Communications/Media
Capital Area Career Center
2201 Toronto Road
Springfield, IL 62712
School (217) 529-5431
pdaniel@caccschool.org

Second Vice-President (Membership)

Dennis B. Dougherty

Thaddeus Stevens College of Tech.
750 E. King Street
Lancaster, PA 17602
School (717) 299-7767
doc@dejazzd.com

Secretary

Kelly Smith

Stevenson HS District 125
One Stevenson Dr.
Lincolnshire, IL 60069
School (847) 634-4000 x1211/x1212
KSmith@district125.k12.il.us

Treasurer

Dennis Daniel

Illinois School for the Deaf
125 Webster
Jacksonville, IL 62650
School (217) 479-4257
Fax (217) 479-4323
orion15@mchsi.com

Immediate Past President

Mark Snyder

Millersville University
Department of Industry & Technology
Millersville, PA 17551
School (717) 871-5547
mark.snyder@millersville.edu

Table of Contents

Editor's Note..... 3

Juried Articles

Large Format Photography..... 5

Digital Photography for Print, Part Two 17

Refereed Articles

Early Career Employees in the Graphic Arts Industries: Testing the GenY Stereotypes 27

Manuscript Guidelines 35

Editor's Note

by Jerry J. Waite, Ed.D, University of Houston

As always, this issue of the *Visual Communications Journal* has something for everyone involved in graphic arts and graphic arts education.

Photography is definitely a primary focus of this Spring 2009 *Visual Communications Journal*. Chris Lantz, from Western Illinois University, highlights the value of the traditional large format camera to teach students photographic principles using both film and digital camera backs. He provides numerous suggestions for student activities and projects that exploit the unique characteristics of these long established and many faceted cameras.

Richard Adams and his colleague Jason Lisi, from Ryerson University, complete a series of two articles that they began in the Spring 2008 issue of the *Visual Communications Journal*. This installment focuses on how digital cameras work, the use of the camera raw format, and how to apply the ICC profiling process to digital photographic images saved in JPEG, TIFF, and RAW formats. Like Chris Lantz, Adams and Lisi provide concrete examples of projects students can complete in class. Their paper will certainly become a must-read for my students!

Finally, Ashley Walker and Patricia Sorce, from the Rochester Institute of Technology, report on their empirical study that compares the job satisfaction experienced by graphic arts employees in three age categories (20–29, 30–44, and 45+). The study concludes that there is “little

support for the stereotype of the spoiled, high-maintenance Gen Y employee in the graphic arts industries.” The implication from the findings of this study support the notion that all graphic arts employees, regardless of age, respond reasonably the same with regards to the opportunity to be creative, personal gratification felt when doing a job well, ability to balance work and personal lives, and potential for career and professional advancement.

As is often the case in our small-but-productive profession, an article that appears in this edition of the *Visual Communications Journal* was authored by one of the *Journal's* reviewers (Chris Lantz). This article was submitted to the same peer-review scrutiny as the other papers and was accepted using a double-blind review process. In addition, a unanimous positive vote by the reviewers to publish the article as a juried publication was received. Documentation regarding the voting on this article is available by contacting me at jwaite@uh.edu.

Thank you to the *Journal's* Editorial Review Board. I truly appreciate the time and effort invested by Cynthia Carlton-Thompson, James Tenorio, Zeke Prust, Bob Chung, Malcolm Keif, Chris Lantz, and Mark Snyder.





Large Format Photography

by Chris Lantz, Western Illinois University

The large format camera is the oldest and most manual camera design currently available other than a pin-hole camera. A large format camera has a front lens board that holds the lens and the camera back that contains the film holder or digital back. A flexible leather or vinyl bellows is found between the front and back. The position of the front and camera back are not fixed and controls are provided so that they can be moved in three dimensions (Figures 1 and 2). A ground glass is used for focusing the projected image from the lens. The lens produces a large image area so that the photographer will not run out of room in the projected image when using

typical camera movements. The large format camera is almost always used on a tripod (Figure 3). The manual workflow of the large format camera can provide students a better understanding of basic camera controls that transfer to any camera. Brooks Institute of Photography is one professional photography school with a tradition in starting its basic students on a large format camera.

With a large format camera students encounter an image directly from the lens that is upside down and reversed from left to right on the ground glass. They focus by moving the distance between the front lens

Five camera movements on a monorail 4x5 camera (left to right and top to bottom): Front lens tilt, front lens swing, camera back tilt, front rise and perspective correction for a tall building.

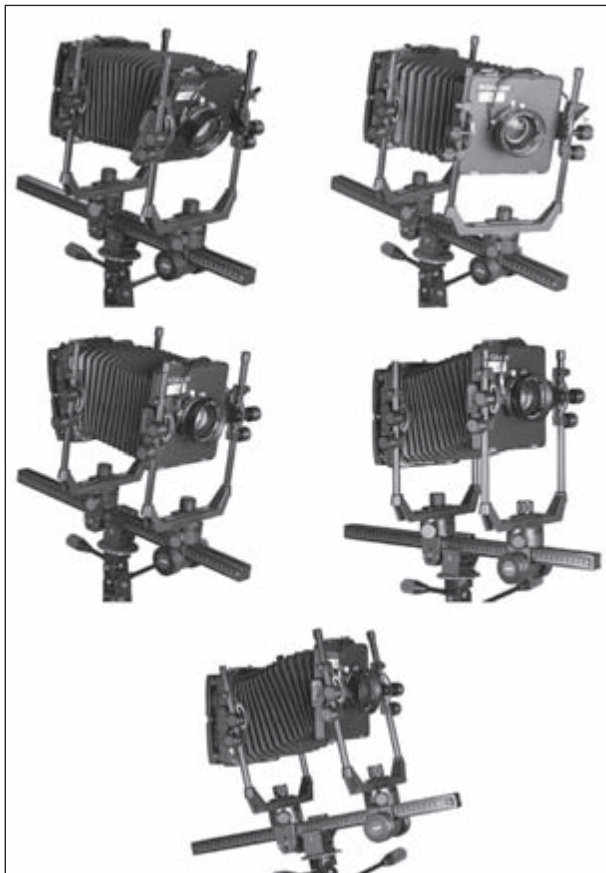

Figure 1

Same as Figure 1 except the bellows was removed for clarity on the lens board and camera back positions.



Figure 2

A vintage Speed Graphic or press camera is a large format camera that was designed to be hand held. Most modern large format cameras are for tripod use only.

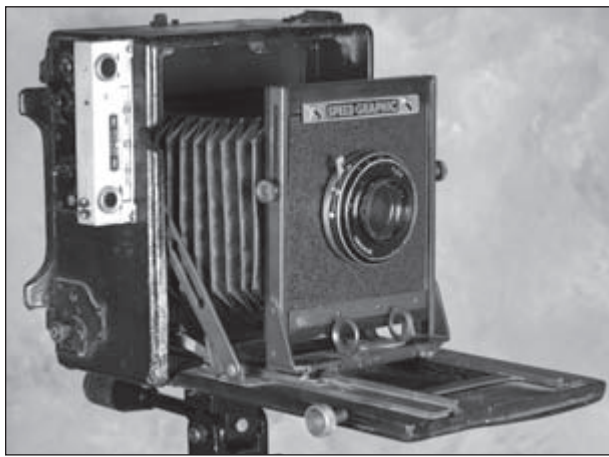

Figure 3

board and camera back. They will then meter the light in the scene and compensate for the length of the bellows for film. For digital capture, a preview scan will first be taken before a final scan, just like on a flatbed scanner. Students will gain an understanding of optical principles embodied in camera movements, some of which are simulated digitally in Photoshop's lens correction and distortion filters. Some photographers wish to perform as many optical corrections as possible in-camera before bringing the image into Photoshop for further adjustment. Images created with a large format camera produce the highest resolution images possible in one exposure with film or digital capture.

Applications for large format photography include commercial illustration for catalog and magazine publication, the reproduction of artwork/paintings for print editions, and for mural sized display prints. Such murals can be viewed at close range for gallery, evidence exhibit, or trade show display. Large format is used commonly for alternative historical processes. Many such processes are done via contact printing and require a negative the same size as the print. Examples include cyanotype or gum bichromate.

Camera Movements

Camera movements allow the lens board and camera back to be in different positions other than fixed and always parallel. Such movements are not possible with a

typical digital or film camera form factor because the lens and film or sensor planes are fixed. Camera movements have control over the plane of focus, perspective, and some shape distortion. Tilting or swinging the front lens board controls the plane of focus. Tilting or swinging only the camera back controls shape. Rising, falling, or shifting the position of the front lens board or camera back controls cropping without moving the camera position. Tilting or swinging both the front lens board and camera back in combination corrects for the distortion of perspective.

One of the most useful camera movements on a large format camera is a front lens board tilt or swing that controls the plane of focus. The point of focus in a scene is a plane that extends through the 3D space of the subject. The plane of focus of a lens is different than the depth of field. The thickness of the plane of focus on the subject is controlled by the f-stop on the lens. Tilting or swinging only the front lens board on a large format camera controls the angle of the plane. Tilting or swinging the lens can change the angle of the plane of focus to better correspond to the subject. This is true even without stopping the lens down for more depth of field as in Figures 4 and 5. None of the plane of sharp focus is wasted when it is adjusted to correspond to a flat subject. In Figure 4, the camera is pointed down toward two flat objects and the front lens board downward tilt movement focused across the plane of the flat scene without stopping the lens down. In Figure 5, the foreground movie camera was not flat but the plane of focus was

Before (left) and after (right) front lens board tilt camera movement toward the table with flat subjects



Figure 4

Same as Figure 4 except the plane of focus extends through a 3D subject in the foreground

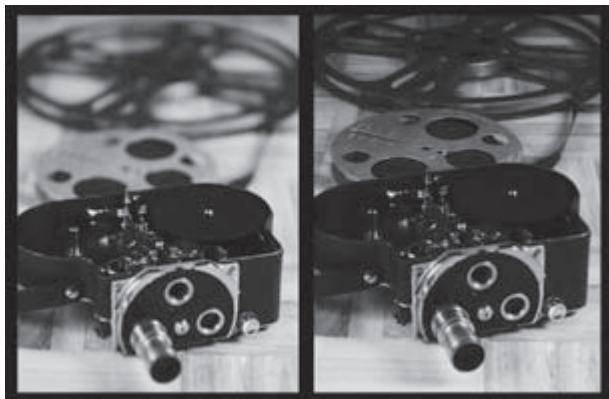

Figure 5

A front lens board tilt was used in conjunction with a stopped down f-22 aperture bringing the 3D objects as well as the plane of the table in focus



Figure 6

adjusted to pass through the lens and the film reels in the background. For the photo on the right of Figure 5, anything above the level of the lens on the movie camera in the foreground passes out of the plane of sharp focus. With subjects that are higher off the surface of the table, stopping the lens down in conjunction with the lens board tilt camera movement can provide a large area of critical sharpness better encompassing both 3D subjects and the table top they are sitting on (Figure 6).

Selective focus effects are possible by tilting the plane of sharp focus of the lens away from an area the photographer wishes to blur. As an example, swinging the front lens board away from the ink well in Figure 7 moved the plane of focus further away from the left side of the photo and provided additional blurring. Tilting the lens is a technique that is provided in other types of equipment such as the tilt/shift lens made by Nikon and Canon and the less expensive Lensbaby products made for interchangeable lens cameras. The tilt lenses cost about the same as a good starting 4X5 large format outfit at \$1000–1900. The Lensbaby is less expensive (\$100–300), but is a primitive one or two element lens designed for soft focus photos only (Figure 8). A home made tilt/shift lens made from an old 105mm enlarging lens and rubber downspouts (Figure 9) is also a possibility for those on a tight budget shooting mostly close-up shots. The plane of focus technique on the large format camera is the most repeatable and has a wider range of control than these alternatives. As an example, for those on a

The plane of focus was swung away from the ink well on the left side in this photo.



Figure 7

A lens tilt on a Lensbaby lens.



Figure 8

A lens tilt on a homemade macro lens



Figure 9

tight budget, one high school teacher used the element of a magnifying glass purchased at a dollar store to create a soft focus lens. This lens was mounted on an old large format camera for the same effect as the Lensbaby (Sawyer, 2008).

Correcting for perspective distortions is another popular use of camera movements. Aligning the front lens board and camera back parallel to the face of a building while the camera is pointed up to include the

whole structure corrects for the distortion of the sides of the building. Another approach to perspective correction is to not point the camera up to include the whole tall building in the shot, but to center the building by raising the position of the lens board and/or lowering the camera back. This front-rise movement was used for the tall building in Figure 10. The front or camera back can be raised or lowered to change the position or cropping of the subject in the camera for situations where the camera cannot be moved. Specialized shift lenses are available for use on interchangeable lens cameras (Figure 11). A greater degree of correction is possible on a large format camera depending on the size of the image circle of the lens. A six-element design provides the biggest image circle. Perspective distortion would also result in pointing the camera down toward a box-like subject with straight sides. The lens board and camera back would be tilted so they are leveled. This insures that the lines on the boxes are straight as on the right of Figure 12. Bubble levels are provided on the front and rear standards of large format cameras to make such perspective corrections easier.

Tilting or swinging the camera back alone distorts and/or blurs part of a subject unless the lens is stopped down as in Figure 13. Tilting or swinging the camera back would result in one side of the image projecting a further distance, making it bigger. The top of the radio on the right image in Figure 13 is distorted because of this greater projected distance.

Image Capture in Large Format

The camera back contains either a digital sensor back or a film holder. The large format camera often uses the same film stock as the 35mm camera but scaled up to a larger 4×5 inch sheet film size. The larger surface area results in a higher resolution by scaling up the number of pixels or grains making up the image. Sheet film is loaded into film holders in the dark using a code notch on the film as a guide to inserting the film emulsion side toward the lens. Sheet film is developed in trays or stainless film hangers and open tanks in the dark. Daylight sheet film tanks or a professional lab can be more convenient. Digital backs available for the 4×5 camera range in price from \$6,500 to \$23,000. Anagramm, Kigamo, and Betterlight in the U.S. are makers of large format scanning camera backs.

This tall building was centered with a front lens board rise without distorting the sides of the building by pointing the camera upward.



Figure 10

The top end \$23,000 Betterlight model is able to capture a resolution exceeding film stock at 416 megapixels, but with a scanning sensor technology that will not make an instantaneous exposure. This renders it useless for moving subjects such as people. It cannot be used with a flash since the image area projected from the lens is scanned with a sensor wand identical to the linear sensor used in a flat bed scanner. The 4X5 camera can be portable in the collapsible field camera form factor (Figure 14). It becomes less portable when the Betterlight back along with its control box, cables, separate battery, and tethered laptop computer are added (Figure 15). Even considering these portability issues, there are landscape photographers who use the Betterlight in the field (Johnson, 2006).

A medium format digital back can be used on a large format camera with a sliding adaptor that includes a

A lens rise movement made on a shift lens.



Figure 11

Uncorrected distortion of the sides of boxes on the left and corrected straight sides on the right using parallel front and back tilts.

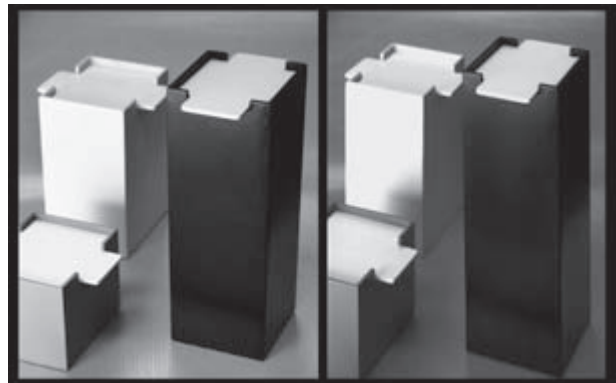

Figure 12

ground glass for focusing and composing the image. The medium format digital backs range from \$7,000–47,000 and can take an instantaneous image. They can also be used with flash and are more portable. Medium format backs start at 16 megapixels and go up to 60 megapixels for the newest models released at Photokina in 2008. The main disadvantage of medium format backs is that they use a small portion (MX sensor size 48 X48 mm) of the 4X5 inch image area and capture less resolution than a scanning back such as the Betterlight.

Before (left) and after (right) shape distortion using a camera back tilt.

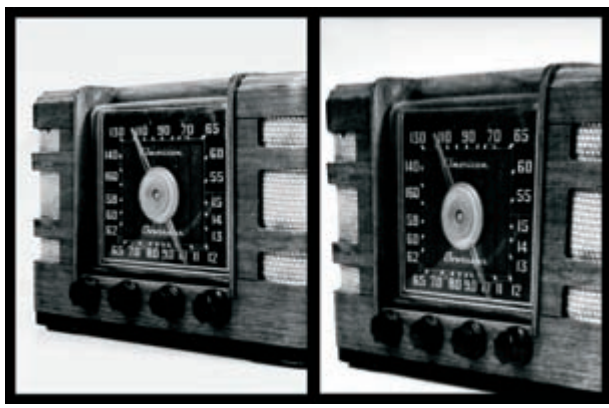

Figure 13

A 4x5 field camera has a lighter wood construction, is collapsible into a small portable package and has the same array of camera movements as a monorail camera.



Figure 14

Advantages of Large Format

Large format cameras were built to last under heavy use and many photographers use equipment that is over 30 years old. There is also a wide current availability of film stock in color negative, color transparency, and black and white. Ninety-six different types of sheet film, made by six different manufacturers with speeds ranging from ISO 25–400, were available at one on-line retailer. Large format cameras take sheet film that is loaded two sheets at a time into a film holder (Figure 16). The sheet film sizes ranged from $2\frac{1}{4}\times 3\frac{3}{4}$ inches to 16×20 inches. The greatest numbers of films were for the 4×5 inch format with 8×10 inch film taking second place. The large number of sheet film types available was surprising considering roll film is more popular.

4x5 monorail camera with Betterlight back, control box, and connected laptop.



Figure 15

Digital Large Format

The Betterlight back uses a linear sensor that scans the projected image of the lens in the large format camera. I have used a 56 megapixel 4000E Betterlight back for the past five years. The back is attached to a control box containing a hard drive. A computer is attached to the control box. The Betterlight scanning software resembles flatbed-scanning software with a preview scan and a final scan (Figure 17). A final scan is typically 45 seconds. The shutter on the lens of the camera is left open and is not used with the Betterlight. Lenses that contain no shutter, such as enlarging lenses, can be used. ISO and line time are the two settings that are provided for exposure in the Betterlight software. Changing the f-stop on the lens is the only control for exposure on the camera itself. Changing the ISO in the Betterlight software has the same effect as on a standard digital camera with the higher ISOs requiring less light but with more noise in the image. The line time controls the speed at which the linear sensor travels across the projected image in the Betterlight back.

Continuous light is necessary with a stationary subject since the Betterlight uses considerable time to scan the image. The 4000E Betterlight requires more light than film to get noise free images. Less light intensity is needed with film because longer timed exposures are

A 4×5 film holder partially inserted into the camera back.

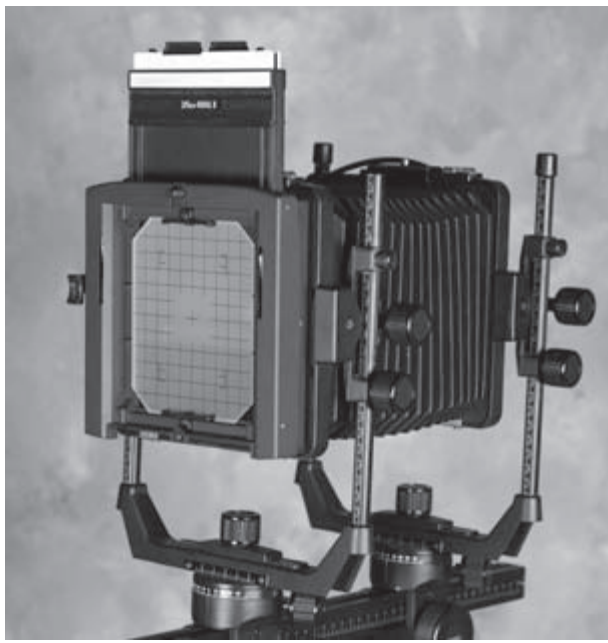

Figure 16

Betterlight Viewfinder scanning software.

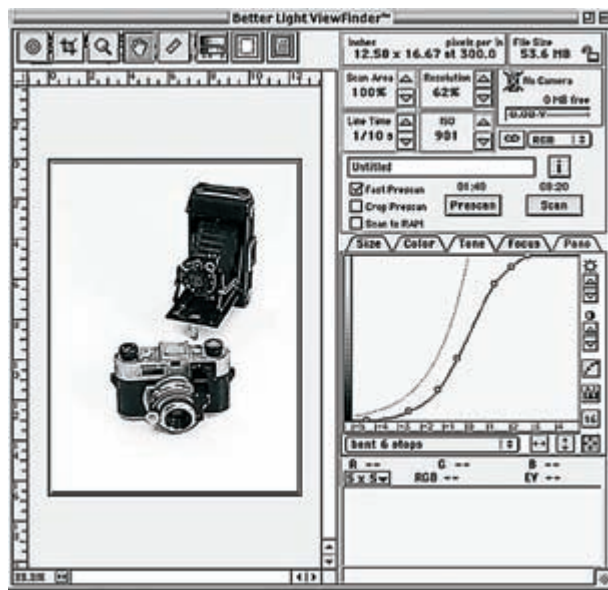

Figure 17

possible than the longest line or scan time on the Betterlight. Newer Betterlight models have greater light sensitivity and resolution. The chief disadvantage of the Betterlight for teaching still life photography is the high

Ultima camera with a front lens board tilt movement.

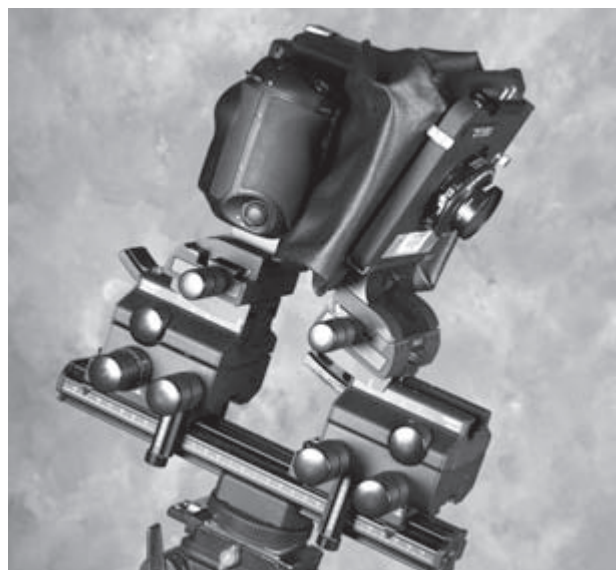

Figure 18

base cost of the system. Considering the past history with pricing of the Betterlight, the cost stays stable but the resolution and light sensitivity increases.

Another digital camera with large format camera movements is the Cambo Ultima (Figure 18). I have used the Ultima in my classes for the past two years. The Ultima uses a DSLR (digital single lens reflex) camera body attached to a bellows and lens in the same configuration as a large format camera but much more compact. A DSLR is attached to the Ultima camera back. A lens that covers the medium format size would be compatible with the camera movements provided. No shutter is required on the lens because the shutter on the camera body is used. The Ultima is most effective at close-up macro photography, as in Figure 19. Depth of focus is at a premium with close up photography because it is diminished the closer the camera is to a subject. The plane of focus control with the front lens board movement is useful for bringing small subjects into focus.

Another assignment for the Ultima is to use a lateral back-shift movement to take several overlapping shots across the back of the camera. These shots are then blended together into a panoramic photo using the photomerge feature of Photoshop (Figure 20). High-resolution murals can then be made with roll paper and the Qimage printing program (Figure 21). This effect can

Close-up taken with an Ultima camera and a front lens board tilt.



Figure 19

also be achieved with a DSLR shift back, which is available for \$250 (Figure 22). Close focus distance between the lens board and camera back with the DSLR shift back makes camera movements difficult without a bag bellows. A bag bellows, like on the Ultima, has no pleats, making a larger range of movements possible without damaging the bellows.

Panoramic shots can be taken with a standard DSLR and blended together with photomerge without even a tripod. The advantage of using the Ultima or the shift adaptor is that the camera angle in relation to the subject says the same. The photographer is taking the different shots within the same projected image from the lens in the Ultima or the DSLR shift back. This results in flawless blending of the photos in photomerge. No adjust-

ment or retouching with the rubber stamp or healing brush is needed. Small stitching or blending errors are often more detectable and not acceptable for commercial studio product photography compared to many landscape panoramas. The Ultima is expensive (\$4,000 without DSLR), but it is versatile considering it can be converted to a large format camera with an accessory kit. The Ultima will not become obsolete as quickly as the DSLR camera attached to it.

Instant Film and Large Format

Polaroid stopped manufacturing its instant film and cameras in February 2008. Polaroid is primarily known as an instant amateur format. Polaroid-type film is also used for equipment with a Polaroid back that may not easily or affordably be adapted to digital capture. Examples include legacy medical or scientific instruments and the large format camera. Considering this fact, it is fortunate that Fuji makes Polaroid-type instant film for the large format camera. Photographers continue to refer to instant film pictures as “Polaroid” even though today they are Fuji products.

Ansel Adams (1978) was a large format photographer who used Polaroid in the field for testing and for teaching. Educators who teach large format photography use Polaroid to demonstrate shooting and lighting techniques and to provide exposure information. A separate digital camera can be used to scout locations for shooting film but does not provide the exact same cropping. It is not as useful as tests of exposure and cropping made with a Polaroid camera back mounted on a large format

Panoramic studio shot created from five overlapping digital files made on the Ultima camera using Photoshop's photomerge feature.



Figure 20

camera. Some of the illustrations in this paper were Polaroids shot with a large format camera in class demonstrations. The original borders on a large format Polaroid can be identified by their angled bottom corners and were retained for illustrations used in this paper. Black borders were used for Betterlight preview images also taken during class demonstrations. As a teacher using the large format camera, it is more convenient to pass a Polaroid print around on location than passing out the digital camera or laptop on a bright sunlit day or in a studio without access to and/or space for a data projector.

The Fuji 4x5 PA-45 pack film back fits in the spring-loaded slot under the ground glass of a large format camera just like the Polaroid back it replaces (Figure 23). It uses a ten print film pack and is \$129. The Polaroid 545

single sheet back is not compatible with Fuji instant film. The film is about the same cost as Polaroid single sheets. Another less expensive option is to use a Fuji PA-145 instant film back or an existing Polaroid 500 back. The PA-145 back is installed on the camera with the standard Graflock compatible connection available on most 4x5 cameras under the ground glass. The print size is smaller at 3¼x4¼ inches and with a cost \$12 for a ten print pack of color film (Figure 24). The same Fujicolor FP-100C color film in a 10-sheet pack is \$29 for the 4x5 PA-45 back. Another advantage of the PA-145 is that two types of black and white and one type of color film are available. Only color film is currently available for the PA-45 in the U.S. Photographers are not discarding their old Polaroid sheet film backs. This is because Fuji Quickload (not instant) sheet film in color negative, transparency,

Mural print made from the panoramic image in Figure 20.



Figure 21

DSLR mounted on a 4×5 camera using a shift adaptor.

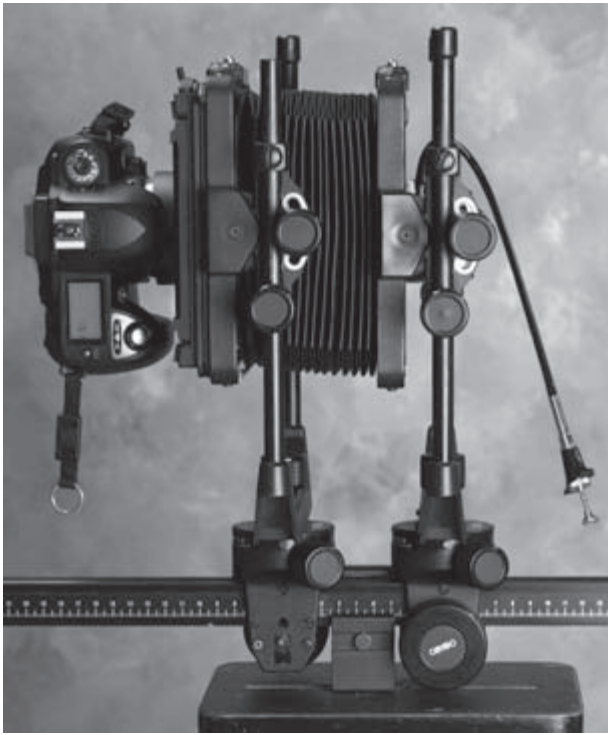

Figure 22

and black and white is available and is compatible with the Polaroid single sheet back. Using such film eliminates the need to load a film holder, reduces the weight and bulk of multiple film holders on location, and is easy to mail to a lab.

Conclusion

Large format camera operation is slower and more deliberate than a DSLR. It can also be more difficult starting out, but is relevant in an educational setting because important optical concepts are gained as a result. In a studio still life context, making photos as rapidly as possible is not always a priority. Slowing the workflow may improve creativity and produce a more considered approach. Such a style is not suitable for some types of action photography but is helpful with still life and architectural photos. Students often spend more time considering composition and lighting options when working in large format.

Fuji PA-45 instant film back on a 4×5 camera.

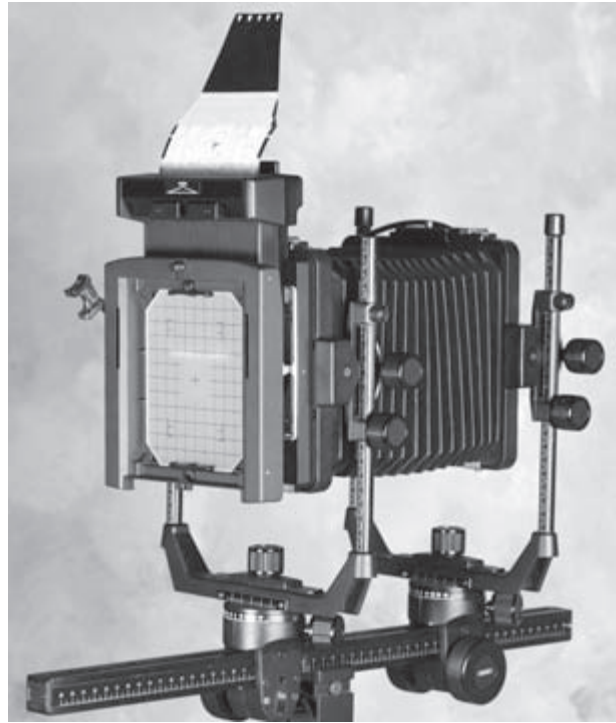

Figure 23

Size and cropping factor of the PA-145 print (left) versus the PA-45 print (right).

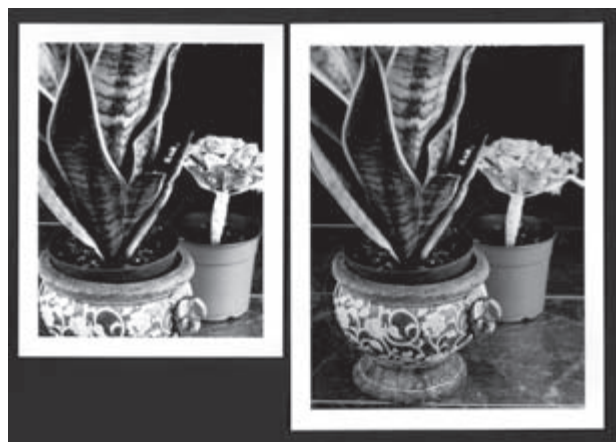

Figure 24



References

Adams, A. (1978). *Polaroid land photography*. New York Graphic Society: Boston, MA.

Johnson, S. (2006). *On Digital Photography*. O'Reilly: Cambridge: MA.

Sawyer, M. (2008, May/June). Through a glass cheaply. *View Camera: The Journal of Large Format Photography*. pp. 38-43.

This is a juried paper.



Digital Photography for Print Part 2: Camera Profiling

by Richard M. Adams II, Ph.D. and Jason Lisi, M.Ed., Ryerson University

Over the past decade, digital photography has come to replace scanning as a method of image reproduction. There are many books about digital photography, but none specifically for graphic arts professionals. The objective of this series is to start a discussion on identifying topical areas that graphic communications students and professionals should know about photography, in order to achieve optimum image reproduction, without necessarily exploring the creative side of photography.

One difference between reprographic photography and artistic photography is that reprographic photos are taken specifically for publication, whether by print, on CD, or on the World Wide Web. The photographer must know how to achieve the optimum image quality that shows off the subject, with all its detail, tonality, and color. Many of the quality control devices and processes used in scanning are also applicable to reprographic photography. In discussing these devices and processes, graphic arts professionals must understand the goals of reprographic photography:

- to get images that have the optimum contrast and detail;
- to take captures that match the colors of the original subjects as closely as possible, given the restrictions of the reproduction media; and
- to achieve consistency in captures, so that photos look the same from one day or week to the next, and from one camera to another.

Part 1 of this article described steps used in optimizing the camera, including setting exposure, white balance, and output ICC profile. In Part 2 we describe factors involved in making ICC profiles of digital cameras, the goal of which is to produce digital images that best match the original scene.

Understanding Digital Cameras

To better appreciate the resulting images taken by a digital camera, it is important to understand the process that the camera uses to convert analog light into digital pixel information. One way to do this is to look at the

different parts of a digital camera that are used to capture scene information, and see how these parts work together in conjunction with mathematics to reproduce a digital representation of a physical scene.

1. **Image Sensors.** There are two basic image sensor technologies that are used in today's mid to high range cameras: charge-coupled device (CCD), and complementary metal-oxide-semiconductor (CMOS). Regardless of the image sensor technology, the goal is the same: to capture light and convert it into an electrical signal. Once light data is converted into voltage, additional circuitry in the camera converts the electrical signals into digital information.
2. **Color Sensors.** In order for a digital image to be successfully captured, light from the visible spectrum must be filtered into its red, green, and blue (RGB) components. One of the most common types of filter used for this process is the Bayer filter, named after its inventor, Bryce Bayer. The Bayer filter uses red, green and blue sensels (sensor elements) to filter light before it is recorded onto the image sensor. Interestingly, the filter has twice as many green sensels than red or blue to mimic the human eye's bias towards green light. The resulting image (called a Bayer Pattern) that is formed after being processed by this filter is essentially incomplete. Each pixel only records one color due to the nature of the filtering process, which means that two thirds of the image data for each pixel is actually missing. In order to get a complete image, the Bayer pattern must go through a complex demosaicing algorithm to interpolate the missing color data.
3. **Demosaicing.** When light enters the camera, it travels through the filter array, and electrical signals are formed on the CCD. These signals contain information about the captured scene, but in this state are really not usable. While each pixel on the CCD represent a specific color (red, green, or blue), the CCD itself is monochromatic, and as a result the signals are not really in color. The process in which each monochromatic CCD pixel is converted to its assigned color value, and then interpolated to include missing colors, is known as demosaicing.

4. **Rendering.** The final stage of the process is rendering. The purpose of rendering is to take the raw information that has been captured and converted, and run it through post-processing color correction to make the final image pleasing to the eye. This process takes into account several factors such as ISO speed, contrast, saturation, sharpness, and white balance. The way images are processed in the rendering stage is highly dependent on the make and model of camera. Each camera vendor has different formulas that are used for different image compositions that are based on years of photographic experience with regards to what the end user will perceive as “pleasing to the eye.” In most cases, the goal of rendering is not make the final image look exactly like the original scene; rather, rendering will “improve” upon the original scene by doing such things as making skies bluer, grass greener, and so on.

In summary, the typical process for capturing a digital image involves analog light travelling through a filter array to be stored as electric signals on an image sensor. The electric signals are converted to digital information, and then mathematical algorithms are used to demosaic the raw data into usable RGB image data. Finally, the RGB data is rendered to produce a final image that is pleasing to the eye (Figure 1). This process is typical for all types of digital cameras, from low-cost point-and-shoot models to high-end studio cameras. Most entry-level point and shoot cameras do not allow for any user intervention during this process, with all the steps happening automatically inside the camera, producing a final pleasing color JPEG or TIFF file. With higher end cameras, such as digital single reflex lens cameras (DSLRs), there is an option to save images as camera raw files. By saving images in camera raw format, users can inflict considerable control over the demosaicing and rendering stages of digital image capture, allowing for greater flexibility and manipulation of the image data.

Internal processing of digital camera files includes demosaicing and color rendering.

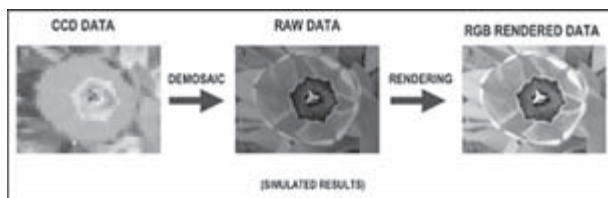

Figure 1

Measured Photography

Measured photography was developed in the 1990s to help deal with the tone compression that occurs when reproducing a transparency. For example, assume that transparency with highlight density 0.30 and shadow density 4.00 (range 3.70) is reproduced on glossy web offset publication stock with paper density 0.10 and halftone shadow density 1.30 (range 1.20). The transparency’s density range of 3.70 is compressed by more than half to 1.20. Measured photography uses scene lighting and exposure metering to produce a transparency with a density range of 1.20.

The advantage of a measured photograph is that its density range is already within the print density range. It requires no tone compression. The photograph is “WYSIWYG,” as it looks more like its printed appearance. Also, multiple transparencies can be exposed with the same settings and reproduced in catalog, ensuring consistency.

The disadvantage is that, since its density range is reduced to that of a print, a measured photograph will have less contrast and color saturation than a standard transparency.

Density. A thorough understanding of measured photography requires knowledge of how density relates to camera exposure. Frank Preucil, while a research scientist at GATF, developed the first reflection densitometer for use in measuring printed color. Density, on a scale of 0 to infinity (in practice, about 0 to 5), has been used to measure color and ink film thickness in prints. Density is an inverse logarithmic function of reflectance (Equation 1):

$$Density = \log \frac{1}{R}$$

where R = reflectance (0–100%)

F/stops. F/stops, or exposure values (EV), refer to a doubling or halving of camera exposure. If exposure time is doubled, then light exposure also doubles. But if the camera’s aperture, or lens opening, is increased by twice the diameter, then exposure increases four times. This is because the amount of light admitted is a function of the lens opening, which is proportional to the square of its radius (Equation 2):

$$Area = \pi r^2$$

r = radius

π (pi) is a constant

Thus, to double exposure requires that the camera's aperture be opened by an amount equal to the square root of double, or 1.414. For this reason, camera aperture settings increase by the square root of 2; for example, from 2, 2.8, 4, 5.6, 8, 11, 16, 22, 32.

Relationship of f/stops to density. Since camera *f*/stops represent exposure differences of 2, their density equivalent is 0.30. This is because of the logarithmic relationship of density to reflectance or transmittance (Equation 3):

$$\log 2 = 0.30$$

From this relationship between *f*/stops and density, it can be seen that the *f*/stop equivalent of a 1.20 density range is 4 ($1.20 \div 0.30 = 4$). Thus, a 4-stop, or “measured,” transparency with a density range of 1.20 would fit within a print density range of 1.20 without tone compression.

Making measured photographs. To make a 4-stop, or measured, photograph, the photographer meters the scene on an 18% gray card, which is set to an EV of 0. The photographer then adjusts lighting to ensure that highlights do not exceed an EV of +2 and that shadows do not exceed an EV of -2.

Since measured photography is set up with scene lighting, the concept applies equally to transparencies and digital photographs.

The Camera Raw File Format

The concept of the camera raw file format is relatively new, and it coincides with the evolution of digital photography, and in particular, digital single reflex lens cameras (DSLRs). In simple terms, the camera raw file format is the digital equivalent to a traditional film negative. The term “camera raw” relates to the fact this particular file format contains all the information captured by the camera's image sensor for a particular scene, without any color conversions or post-processing. Since camera raw files are not restricted to any specific process parameters, they can be manipulated, or “digitally developed” with a high degree of flexibility, allowing for user-controlled demosaicing and rendering. For this reason, there is a greater likelihood that a camera raw image can be processed to match (or improve upon) an original scene when compared to an automatically processed

JPEG. In some cases, user intervention at the camera raw file stage can even correct some common image issues such as blown out highlights and incorrect white point.

Currently there is no standard for the camera raw format as there exists for other image formats like TIFF and JPEG. Each camera vendor has created its own proprietary system for capturing raw data, and most camera vendors are highly protective of the technology behind their process. This makes it difficult for third party software developers to offer camera raw support in their applications, as not only do they have to code in support for multiple “types” of camera raw formats, but they actually have to reverse engineer that support by taking apart a camera raw file from each camera type.

Just like a negative is used to create a final print, a camera raw file is used to create a final digital image. A camera raw file is really a digital master that can be used to create many different variations of an original scene; however, the camera raw file itself is not functional as a final image file. In order to get a usable image from a camera raw file, demosaicing and rendering must be applied. When a user chooses to work with camera raw as opposed to letting the camera do all the work, the task of demosaicing and rendering an image falls to specialized software called camera raw editors. Most camera raw editors fall neatly into one of two categories: vendor supplied applications or third party applications.

Vendor-Supplied versus Third-Party Camera Raw Editors. All digital SLR cameras come with software that can be used to download and process images from the camera. These applications will have the inherent ability to process camera raw files into some sort of usable image format, such as TIFF or JPEG. There is one significant advantage to using the software that came with your camera to process camera raw files: since the camera vendor knows the exact science behind its own camera raw format, the demosaicing part of the image post-processing will be very accurate because no guess work is needed to “decipher” the technology behind the camera raw file. The demosaicing done by third party applications will not be as accurate because the demosaicing algorithm used was created using a reverse-engineering process. In contrast, vendor supplied software tends to be less feature rich in terms of their rendering functionality and ICC Profiling capabilities when compared to third party products.

Regardless of which type of software you use to process your camera raw files, there is one very big advantage that they all share: non-destructive image editing. When you adjust the rendering settings for a camera raw image, you are not actually adjusting the image itself. Most software stores the settings for a particular image file as a separate data file that is used to process the information. The original camera raw data remains unaltered. This means that at any time the image can be reverted back to its non-rendered state, and that several different rendering settings can be created from one camera raw file.

Most professional photographers and production facilities opt for the larger feature set of third party camera raw editors to process their files. There are many different options out on the market that have varying degrees of complexity and functionality. It is difficult to rate the products against each other since there are so many factors that can impact the success of an outcome. For example, one camera raw editor may work particularly well for a particular make and model of camera, but not another. A user may choose one application over another based on need. For example, Adobe's Camera Raw Plug-in has good rendering control, but limited functionality in assigning custom camera profiles. Many professional photographers like to use a product called Capture One, since it is created by Phase One, and has built-in support for high-end Phase One digital camera backs as well as most other popular digital camera types. Some of the more common third party applications and their features are described later; however, it should be noted that there are many other products available on the market, and this is just a sample of what is currently available.

Working with Camera Raw

There are both advantages and disadvantages of working with camera raw files as opposed to JPEG or TIFF. Like any good decision, it is best to weigh the pros and cons of each, and choose the solution that is best for you. Table 1 highlights some of the advantages and disadvantages of working with camera raw versus non-camera raw such as JPEG or TIFF.

Generally speaking, it makes sense to use camera raw when the difference in potential quality will be noticeable. Camera raw offers greater flexibility for color critical shots done in high-end studio photography, for magazines, and product brochures, but may be unnecessary for images that will be used in lower quality production work, such as newspaper inserts.

ICC Profiling Digital Images

Scanner profiling. ICC Profiling was originally developed for scanners. Its objective was to enable operators to scan transparencies and prints that “match the original.” To profile a scanner, the operator scanned a test target (ANSI IT8.7 or ISO 12641) containing over 200 color patches to produce an RGB TIFF file. The scanned target characterized the scanner's color reproduction capability. To represent the target's “true” color, each of the target patches had been colorimetrically measured. The ICC profile itself was made with a profiling application. The operator opened the scanned TIFF file and the measured reference file. The application compared the RGB values of the scanned color patches with the measurements of the patches, then calculated a color conversion. The conver-

Table 1: Camera Raw vs. JPEG and TIFF File Formats

Camera Raw		JPEG or TIFF	
Advantages	Disadvantages	Advantages	Disadvantages
Contains the full set of data captured from the scene	Requires post-processing to get a usable file	No Post-processing required	Data from the scene has been clipped and manipulated
Can perform non-destructive image editing	Requires some knowledge of image manipulation and color correction	No knowledge of image manipulation and color correction required	Not a digital master – cannot perform non-destructive image editing
Full control over rendering	Proprietary file formats, no standardization	Open standards for file formats, more predictable	No Control over rendering
More flexibility with ICC profiling through third party applications	Larger file sizes need more storage space	Smaller file sizes due to compression (JPEG/LZW)	Limited control over ICC profiling

sion changed the scanned colors to match the original as closely as possible.

Camera profiling. The idea of profiling digital cameras has been around for a few years now, and there are several products on the market that will allow you to do this. There are some unique variables and considerations that must be considered when profiling a digital camera that do not apply to other devices. When you profile a scanner for example, the external variables that could affect the output of the scanner are minimal. The scanner bed or drum is essentially a controlled environment that is relatively unaffected by external factors. Digital cameras, on the other hand, are the exact opposite. Even small changes in things like lighting conditions, and even room temperature, can have a drastic affect on the way a scene is captured. For this reason, it is not really feasible to try and create a single camera profile that would be applicable to all situations. Furthermore, camera profiling is not very practical for images that will be taken outside of a studio, since the variability (inside vs. outside, day vs. night, cloudy vs. sunny, etc.) is too great to predict. Within a studio, the environment can be well controlled, making profiling more plausible. Even so, each camera may need several profiles to compensate for things like different camera lenses and different lighting intensities.

Profiling a digital camera has the same objectives and concept as profiling a scanner. The photographer sets up a

X-Rite's Macbeth ColorChecker SG (semi-gloss) target was developed for profiling digital cameras. The color patches are made from precisely made paint chips and have a larger gamut than photographic paper-based targets.

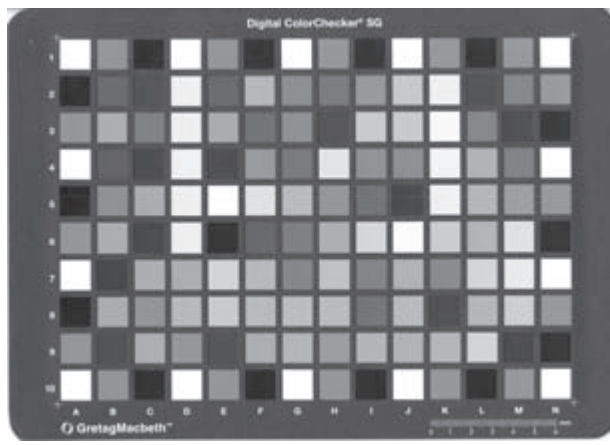

Figure 2

scene, lighting, and the camera to make a properly exposed capture. Before or after capture, the photographer places a chart of color patches into the scene so that it is square with the photographic frame, and captures the target (Figure 2). The profiling application compares the patches' RGB values with the target measurements, and calculates a conversion to match the colors. The results of profiling are that (1) each capture has colors that match those of the original scene more closely than they would without the profile, and (2) captures from multiple profiled cameras can be used in the same publication with minimal noticeable differences (Figures 2 and 3).

Profiling Strategy

ICC profiling merely records the color reproduction characteristics of devices. To get the highest quality and most consistent color, the operator must first set up the

Before and after images of camera ICC profile.

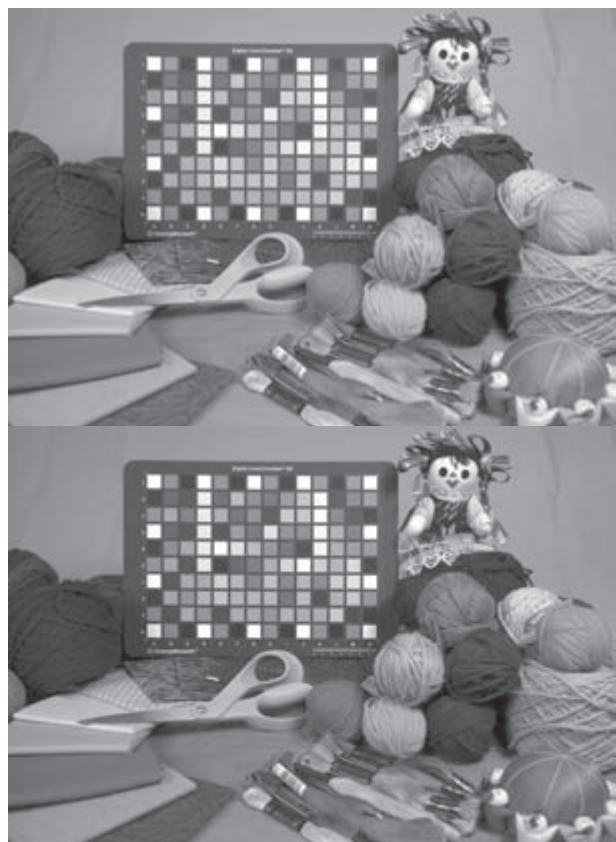

Figure 3

The 4 Cs of color management is a hierarchy that illustrates the step-by-step procedure necessary in profiling a digital camera or other device.

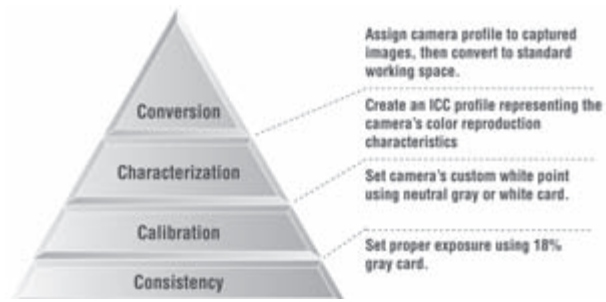

Figure 4

device, a process referred to in the “4 Cs” of color management (Figure 4).

Consistency. The first “C,” consistency, refers to optimizing the device. For a digital camera, optimization refers to setting the lighting and exposure to capture the subject’s full tonal range and detail. This is analogous to setting the highlight and shadow in scanning. Below is a step-by-step procedure for setting exposure.

1. Set up the scene, mount the camera on the tripod or stand, set up the lighting, set the camera to manual exposure, and adjust the lens zoom and focus to get the desired composition.
2. Place an 18% gray card, such as the Macbeth Gray Card (Figure 5), in the scene. For the most accurate reading on the card (not other parts of the scene), set the camera’s internal meter on spot or center-weighted mode. Set focus to manual so the camera won’t attempt to focus on the card. (Most autofocus mechanisms require an edge to focus on.)
3. By changing the aperture and/or shutter speed, meter an exposure value of 0 EV on the gray card. (0 EV is the correct exposure, -1 EV is 1 f/stop underexposed, and +1 EV is 1 f/stop overexposed.)
4. Remove the gray card. The scene should be at the correct exposure.

Calibration. Calibration has been defined as “setting a device to a known specification.” For a digital camera, this could include the exposure, as described above, as

Before profiling, camera consistency (optimization) must be achieved by setting camera exposure with an 18% reflectance gray target, such as this X-Rite MacBeth Gray Card.



Figure 5

well as the use of a custom white balance setting. Custom white balance calibrates the camera’s sensor to the lighting, neutralizing any color casts in the photo. This is analogous to gray balance in scanning. The procedure for setting custom white balance is similar on most cameras.

1. Set up the scene as described above and set exposure.
2. Place a colorimetrically neutral (in L*A*B value, a*b* = 0,0), white or gray card in the scene.
3. Set the camera’s white balance to the card. This usually involves activating the custom white balance control (Figure 6), then pressing the shutter release button.

Characterization. Characterization refers to the actual profiling process itself, i.e., capturing the profiling target and making the ICC profile. To do so:

1. Set up the scene, and set exposure and custom white balance as described above.
2. Place an ICC profiling target, such as the Macbeth ColorChecker SG, into the scene so that it is square with the camera and evenly illuminated.
3. Capture the target and save as a JPEG or TIFF file.

After setting camera exposure, custom white balance must be set to neutralize the effects of scene illumination, as in this example with X-Rite's Macbeth White Card.

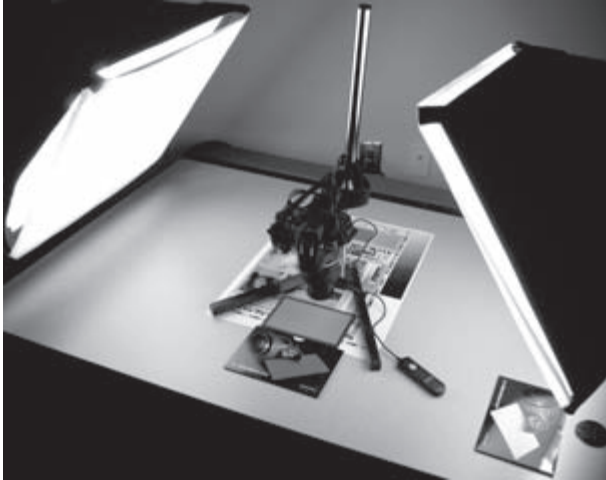

Figure 6

4. In a color management profiling application such as X-Rite i1 Match (Figure 7), ProfileMaker, or Monaco, open the captured target, open the reference file of target color measurements, and make the profile.

Conversion. Conversion is the process of changing digital color values in the captured file, using two ICC profiles (source and destination), to achieve a match. Conversion can be done in a workflow program, such as Adobe Photoshop, either in the program itself or at the time of output.

In workflow, color management profiles are described as source and destination. In digital photography, the camera ICC profile is the source profile. This profile could be assigned using Photoshop's Edit > Assign Profile command (Figure 8). A photo could either be left in the color space of the custom ICC profile, or converted to a standard working space such as Adobe RGB. In this case, Adobe RGB would be the destination profile. For a large print job (e.g., a catalog or web site), converting all photos from the custom ICC profile to Adobe RGB ensures that photos from different cameras, photographers, and studios will have a consistent appearance.

Camera Raw and ICC Profiling

By its very nature, camera raw is not standardized, and there are no real best practices with regards to "proper"

Digital camera profiling can be performed with an application such as X-Rite's i1 Match.



Figure 7

camera raw conversions. As a consequence, ICC profiling is not something that is usually associated with camera raw images. Recent research into the area of camera raw profiling has shown that, if done correctly, camera raw image conversions can create consistent, repeatable profiling results.

Workflow diagram showing source profile.

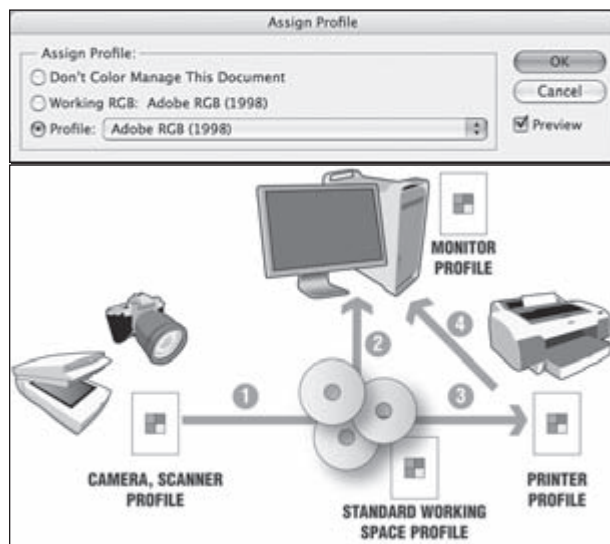

Figure 8

As mentioned earlier, when you shoot a scene with a digital camera as a TIFF or JPEG, two automatic processes are applied to the scene data within the camera. First, the raw image sensor data is demosaiced and translated into RGB color data. Second, the color data is color rendered, or corrected, to achieve what the camera vendor feels is pleasing color. Both of these processes are proprietary and vary from camera vendor to camera vendor. When the digital image is taken as a TIFF or JPEG, there is no user intervention in this process. The result is an image that has already been color corrected. If this image is then used to create a camera profile, in essence you are creating a profile from an image that is already color adjusted. Ideally, an ICC profile should be created from a device that is calibrated but not color managed.

Using camera raw images can be a very reliable way to overcome the limitation of automatic color adjustments that are applied to TIFF and JPEG images. Using a good camera raw editor, like the Adobe Camera Raw Plug-in, or Capture One Pro, a camera raw image can be opened in a “linear” state. Essentially, a linear camera raw image is the closest representation to what the raw image sensor data looks like after demosaicing without any color rendering. The result is an image that is usually quite dark and flat looking. In the realm of color management, this would be the equivalent of printing a proof on a printer with color management turned off. If the white

point of the linear raw image is then set to a standard (for example R236 G236 B236), the resulting image is a calibrated file without color management applied. If this image is exported as an RGB TIFF and used to create a camera profile, the process used most closely represents the process used to create more traditional ICC profiles. The profile is more accurate, and does not include the unpredictable conditions of proprietary, vendor specific color rendering attributes.

In summary, for really accurate results for camera profiling, it can be argued that the profile image should be shot in camera raw. When the image is opened in a camera raw editor, it is important that any rendering settings be removed, creating a “linear image.” A camera raw image without rendering will generally appear dark and flat. The other important thing is to make sure there is no embedded profile in the image that will alter how the image looks. Save the image out of the camera raw editor as an RGB TIFF without an embedded profile. This will be closest representation of the camera raw data that can be achieved in a demosaiced, rendered image. This image can then be brought into a profiling software package to create the custom profile. This should give the truest results, since you are creating the profile based on the raw data of the camera, not something that has already been color corrected and adjusted.

Third-Party Camera Raw Editors and ICC Profiling

There currently exists a lot of choice for photographers wishing to invest in a third party camera raw editor. Some programs, such as Adobe Lightroom and Apple Aperture cater more towards photographers looking for enhanced creativity with their images.

Products Phase One's Capture One Pro and Bibble Pro (Bibble Labs), and Raw Developer have similar features to that of Aperture and Lightroom, but add more production functionality through enhanced ICC Profile control. This is a significant addition for anyone wishing to explore the idea of custom camera profiling. All three of these products allow the user the ability to set different camera profiles and device profiles. Each program comes with a good set of generic profiles for almost all digital SLR cameras on the market. If the user has gone through the process of creating custom camera profiles,

they can also be used. At the output stage, the user can also assign an output, or destination, profile for whatever color space the image is being saved to. For example, Adobe RGB (1998) may be selected for an RGB image, while GRACoL2006_Coated1v2 may be selected for CMYK images. Again, if the user has a custom output profile—for example a press profile—it can be used here.

Conclusion

In conclusion, ICC profiling is a quality-control process that can be used with digital photography in printing. It helps ensure that captured photographs match the original scene and subjects as accurately as possible. As a result, it helps synchronize the output from multiple cameras. The camera ICC profile is applied by assigning it to camera captures. In a color-managed workflow, captures should be converted to a standard working space for transmittal to the client or end-user.

Exercises in Photography

Following are some suggestions for useful lab exercises that enable students to visualize the advantages of ICC camera profiling and measured photography.

1. ICC camera profiling. Set up a studio shot, preferably with multiple memory colors (red, green, blue) and grays. Expose the shot. Then include a Macbeth Color Checker SG camera profiling target in the scene, aligned perpendicular to the camera, and expose the same shot. Make an ICC profile with X-Rite i1 Match, ProfileMaker, or other profiling application. Open the original photo in Photoshop. Apply the profile with Edit > Assign Profile. Note the difference. Which photo matches the original scene more closely?
2. Measured photography. Set up a studio shot. Meter the exposure to EV 0 on an 18% gray card. Check the highlight and shadow, and try to make the scene range greater than 4 EV, like -3 to +3 EV. Expose the “normal” shot. Then readjust the lighting to make a “measured” photograph. Lighten the shadows so the EV range is 4 (e.g., -1 to +3 EV). Open both images in Photoshop. Preview both photos (View > Proof Colors). Turn on the Gamut Warning (View > Gamut Warning). Which photo’s contrast and saturation changes the least when previewed in CMYK? Which photo has the smallest number of out-of-gamut colors?

References

- Adams, R. M., J. Lisi, N. Gilewicz, and M. Habekost, A. Seto, A. Sharma. (in press). *Digital Photography for Print*. PIA/GATFPress: Sewickley, PA.
- Adams J, Parulski K, and Spaulding K (1998). Color processing in digital cameras. *IEEE MICRO* 18 (6): 20-30.
- Adams, R. M., A. Sharma, and J. Suffoletto. (2008). *Color Management Handbook*. PIA/GATFPress, Sewickley, PA.
- Adams, R. M. Digital Photography and Sign Making. *Sign Business*, August 2007, pp. 89–91.
- Adams, R. M. Profiling Digital Cameras. *Sign Business*. February 2006.
- Brehm, P. (1999). *Introduction to Densitometry*. Graphic Communications Association, Alexandria, VA.
- Nakamura J. (2005), *Image Sensors and Signal Processing for Digital Still Cameras*. CRC Press,
- Lisi, J. and Sharma, A. (2007). *Analysis of Color Rendering in Digital Cameras*. TAGA 59th Annual Technical Conference, Mar 18–20, 2007, Pittsburgh.
- Lisi, J. (2008). *Predictive Color Rendering of Camera Raw Images Using ICC Profiles*. TAGA 60th Annual Technical Conference, Mar 16-19, 2008, San Francisco.
- Longere P, Zhang XM, and Delahunt PB, Brainard DH. (2002) Perceptual assessment of demosaicing algorithm performance. *PROCEEDINGS OF THE IEEE* 90 (1): 123-132, Jan 2002, Sp. Iss. SI.
- Nakamura, J. (2005). *Image Sensors and Signal Processing for Digital Still Cameras*. CRC Press, Boca Raton, FL
- Pasley, R. (1999). Measured Photography: Balancing the Lighting Equation for Offset Printing. *Professional Photographer*, July 1999.
- Sharma, A. Digital camera profiling. *PhotoTechniques*, September 2003.

This is a juried paper



Early Career Employees in the Graphic Arts Industries: Testing the GenY Stereotypes

by Ashley S. Walker, M.B.A.; Patricia A. Sorce, Ph.D., Rochester Institute of Technology

Introduction

As the Baby Boomer workforce continues to move towards retirement, the next great change for American businesses will be the continued rise of Generation X (born between 1965 and 1985) and the introduction of Generation Y (born between 1986 and 2002) workers into the workplace. Currently, Generations X and Y together comprise 45% of the workforce, and workers under 34 years of age will represent approximately 60% of the full-time workforce in the United States by 2010 (Westerman & Yamamura, 2007). Executives and mid-level managers alike wonder how this will affect their companies and whether they will be able to attract and retain these younger workers.

The purpose of this research is to determine if there are generational differences in job satisfaction among employees of the graphic arts industries. To set the stage, we will first review the literature on the relationship between job satisfaction and demographic characteristics. Then, we will discuss the specific characteristics of the youngest generation joining the work force, the Gen Yers.

Relationships between Job Satisfaction and Personal Characteristics

Several personal characteristics have been reported to affect job satisfaction, but age is one that has received a great deal of attention (Oshagbemi, 2003). As people progress through the career life stages, their job satisfaction is expected to increase (Westerman & Yamamura, 2007; Jepsen & Sheu, 2003). As individuals gain more work experience, they will be able to make progress towards their ideal work situations and they will therefore report higher job satisfaction. However, research does not always provide support for this progression. In a 25-year study of 169 high-school graduates, average job satisfaction scores remained the same during the adult years. It was average job congruence (measured by the similarity between the individual's major in college and the position held at the time of the survey) that increased significantly with age (Jepsen & Sheu, 2003). Davis (2004) also found no evidence to support the hypothesis that older people

tend to be more satisfied with their jobs than younger people, and no statistically significant generational differences have been found for job satisfaction in recent research (Macky, Forsyth, & Boxall, 2008).

In keeping with academic research on this topic, the popular media have also written a great deal about the generational differences in worker attitudes and behavior. One theory that is used as a basis for this discussion is cohort theory which posits that each generation has its own 'personality.' Cohorts are defined as a group of members who were "born in a limited span of consecutive years [ergo, a generation] and whose boundaries are fixed by peer personality" (Glass, 2007, pp. 98-99). The newest generation to reach adulthood is Generation Y, also known as the Millennials or the Echo Boomers. An analysis of the popular media reveals that Generation Y is reported to have different expectations regarding aspects of work than do employees from other generations. These include: work/life balance, personal growth, employer policies and structure, management styles, salary/benefits, meaningful work, working in teams, parental involvement, entrepreneurship, changing jobs, importance of friendships, technology, and self-worth. These findings are summarized in Table 1.

With the changes in the composition of the workforce, employers are strategizing how best to recruit and retain younger workers (Armour, 2005; Spiro, 2006). The purported key to keeping Generation Y workers is changing policies and company structure in order to keep them happy at work. An example is online shoe retailer Zappos, where "...[a]ctual work actually happens, despite goofy parades, snoozing in the nap room, and plenty of happy hours" (Safer, 2007). Of the 15% of employers who have changed or implemented new policies/programs to accommodate Gen Y workers, 57% have changed work schedules, 33% have increased their recognition programs, 26% have increased access to technology, 26% have increased salaries and bonuses, 24% have added more ongoing education programs, 20% have started paying for cell phones, Blackberrys, and other communication devices, 18% have added more telecommuting options, and 11% have added more vacation time (CareerBuilder.com, 2007).

Table 1: Work Attitude Stereotypes of Generation Y

Dimension	Research Conclusions
Work/Life Balance	Generation Y is not interested in making work their life. Instead, they want to make their jobs accommodate their family and personal lives (Armour, 2005; Spiro, 2006). Their personal commitments take priority over work schedules (Safer, 2007).
High Maintenance, High Expectations	Generation Y is characterized as having high expectations for themselves, their employers, and also for personal growth, even in entry-level jobs (Armour, 2005; Spiro, 2006; Trunk, 2007). They have a 'speak your mind philosophy', and they don't take orders without questioning everything (Armour, 2005; Hira, 2007; Martin, 2005).
Management Styles	Gen Yers are purported to need more feedback than other generations (Armour, 2005). Praise is especially important for them (Safer, 2007; Spiro, 2006).
Salary/Benefits	Gen Yers expect to be paid more and get farther faster in return (CareerBuilder.com, 2007). Many Generation Yers pursue graduate degrees because they have a high regard for education (Spiro, 2006), and they ask for more in return for their investment.
Meaningful Work	They want to make an important impact at their job right away, and they are reluctant to perform tasks that lack depth due to their greater need to feel valued (Armour, 2005; Spiro, 2006; Rowh, 2007)
Working in Teams	Generation Y is reported to 'love' working in teams, especially ones that are fluid and can adapt to the needs of the problem to be solved (Rowh, 2007). Teams of peers are reported to be more comfortable for Gen Yers to work on, as they are used to communicating with people their own age (Jayson, 2006).
Entrepreneurship	They have seen their parents and other adults deal with changes in corporate America that often resulted in the loss of jobs. This has led to the idea of being 'free agents', where entrepreneurship is a safety net (Trunk, 2007).
Changing Jobs	Many Gen Yers do not expect to stay in a job or even career for too long (Armour, 2005). Many also think that they can 'get more' by trying new companies and careers (Safer, 2007), and it is also a way out of companies when no career development opportunities are presented (Trunk, 2007). Gen Yers also are unwilling to compromise, and rarely settle for a job when they think they can do better elsewhere (Gerdes, 2007; Rowh, 2007).
Self-Worth	Generation Yers are reported to have been the center of attention and to have obtained many awards and accolades as they've grown up (Jayson, 2007; Safer, 2007). Since they have been told that they can be anything they imagine since birth, they believe this, and are "determined to live their best lives now" (Hira, 2007).

In conclusion, much of the popular media on this topic contains anecdotes indicating the vast differences that Generation Y is bringing to the workplace. These range from evidence on generational gaps in communication styles and job expectations (CareerBuilder.com, 2007) to statements that "[t]he workplace has become a psychological battlefield, and the millennials [Generation Y] have the upper hand" (Safer, 2007). Although these

anecdotes are compelling, there is limited empirical evidence of generational differences from a human resources management perspective (Macky et al., 2008, p. 1). Westerman and Yamamura (2007, p. 152) agree, stating, "... the influence of work environment preference differences between the groups [Baby Boomers as compared to Generations X and Y] remains empirically unverified and untested." Additionally, the most vocal

proponents of generational differences tend to be those with something to sell, be it consulting services or research on Gen Y (Read, 2007).

Therefore, since there is little empirical evidence that generational differences do indeed exist, the purpose of this study is to test if there are generational differences in attitudes towards work for Gen Y workers versus that of older workers employed in the graphic arts industries. That is, does job satisfaction vary by age?

Methodology

Procedure

The survey was administered using an online survey service. In April, 2008, an e-mail was sent to the alumni of RIT's School of Print Media inviting them to complete the survey. The 1,845 alumni contacted were those who had provided their e-mail addresses to the RIT Alumni Office and are a subset of all graduates. Respondents were offered a chance to win one of two iPod Nanos. Reminder e-mails were sent one week after the initial e-mail was distributed. The final response rate was 24%,

yielding 442 respondents. Of these, 332 were currently working full-time.

The two primary dependent variables were overall job satisfaction (measured on a 7-point scale where 1 = Completely Satisfied and 7 = Completely Dissatisfied) and 23 job facet satisfaction questions (measured on a 5-point scale where 1 = Very Satisfied and 5 = Very Dissatisfied). The job facets are listed in Table 3. The primary demographic variables were age, gender, and current salary.

Results

The industry employment profile indicated that 29.6% of the respondents work at commercial printing firms, 8.3% work at publishing firms, 3.9% work at advertising firms, 3.9% work at in-house corporate communications/marketing departments, 3.3% work at in-house educational/non-profit print shops, 1.4% work at design firms, 1.1% work at in-house corporate print shops, and 0.6% work at in-house educational/non-profit communications/marketing departments. Almost half of the respondents (47.6%) indicated "other" types of firms and include categories such as information technology, education,

Table 2: Demographic Profile of Respondents

Questions	Total SPM	20 - 29 years	30 - 44 years	45+ years
Q2: Gender:				
<i>Net Answering</i>	n=419	n=117	n=131	n=169
Male	70.4%	45.3%	70.2%	87.6%
Female	29.6%	54.7%	29.8%	12.4%
Q4: What is your country of birth/origin?				
<i>Net Answering</i>	n=424	n=118	n=132	n=174
United States	90.8%	88.1%	90.9%	92.5%
Q6: Degree achieved?				
<i>Net Answering</i>	n=421	n=116	n=133	n=171
Bachelors	68.2%	69.8%	60.9%	73.1%
Masters	28.5%	29.3%	39.1%	19.3%
Q8: Current work status				
<i>Net Answering</i>	n=428	n=118	n=133	n=174
Employed Full-time	76.4%	79.7%	85.0%	67.8%
Q16: Annual income from current job:				

Table 2: Demographic Profile of Respondents

Questions	Total SPM	20 - 29 years	30 - 44 years	45+ years
<i>Net Answering</i>	n=357	n=105	n=119	n=133
\$14,999 or less	2.0%	2.9%	3.4%	--
\$15,000 - \$19,999	--	--	--	--
\$20,000 - \$29,999	3.1%	4.8%	2.5%	2.3%
\$30,000 - \$39,999	8.4%	15.2%	4.2%	6.8%
\$40,000 - \$49,999	12.6%	21.9%	10.9%	6.8%
\$50,000 - \$59,999	15.4%	22.9%	12.6%	12.0%
\$60,000 - \$69,999	11.5%	20.0%	9.2%	6.8%
\$70,000 - \$79,999	11.2%	5.7%	15.1%	12.0%
\$80,000 - \$89,999	10.4%	5.7%	14.3%	10.5%
\$90,000 - \$99,999	4.2%	--	4.2%	7.5%
\$100,000 or more	21.3%	1.0%	23.5%	35.3%
Q20: How closely related to your current job is your most recent degree attained?				
<i>Net Answering</i>	n=336	n=100	n=109	n=127
Highly Related	60.7%	65.0%	58.7%	59.1%
Moderately Related	21.7%	19.0%	25.7%	20.5%
Slightly Related	8.9%	13.0%	5.5%	8.7%
Not at All Related	8.6%	3.0%	10.1%	11.8%
Q22: How important is your graphic communications degree to your employer?				
<i>Net Answering</i>	n=334	n=99	n=109	n=126
Very Important	31.1%	41.4%	28.4%	25.4%
Important	29.6%	31.3%	30.3%	27.8%
Somewhat Important	20.7%	17.2%	17.4%	26.2%
Neutral/No Effect	8.7%	4.0%	11.9%	9.5%
Somewhat Unimportant	1.5%	2.0%	1.8%	0.8%
Unimportant	4.8%	1.0%	5.5%	7.1%
Very Unimportant	3.6%	3.0%	4.6%	3.2%

consulting, and packaging. The complete demographic profile of the respondents is presented in Table 2.

The mean overall job satisfaction rating on the seven-point scale where 1 = "Completely Satisfied" was 2.33. To test whether there were any generational differences in overall job satisfaction, we created three age groups roughly equal in size: 20-29 years of age (n=100), 30-44 years of age (n = 109), and 45 or more years of age (n= 127). The oldest age group

was most satisfied with their jobs (mean = 2.15), and the youngest group was least satisfied (mean = 2.49), with the middle-age group in between (mean = 2.39). Though this trend was in the expected direction, an analysis of variance revealed that these differences were not statistically significant (ANOVA, $F=2.675$, $p=0.070$).

Next, a regression analysis was conducted using three demographic items as predictors for overall satisfaction.

The demographic items tested were gender, age, and salary. The adjusted r^2 value of 0.079 indicates that only about 8% of the variation in overall job satisfaction can be explained by these demographic items. An ANOVA test revealed that this relationship is statistically significant, with $F=9.947$ and $p<0.0001$. However, salary was the only item shown to be a statistically significant predictor in the model ($\beta=-0.290$, $p<0.0001$).

Average job facet satisfaction ratings are found in Table 3. An analysis of variance was computed on each

facet with age groups as the independent measure. Of all the job facets, only four were found to be statistically significant:

- Opportunity to be creative (oldest age group most satisfied),
- Personal gratification you feel from doing your job (oldest age group most satisfied),
- Ability to balance work and the rest of your life (oldest age group most satisfied), and

Mean Job Facet Satisfaction Scores by Age Group

Facet	Overall Mean*	20-29	30-44	45+
Relationships with coworkers	1.85	1.94	1.87	1.76
Quality of service/product provided/produced	1.87	1.96	1.86	1.80
Flexibility to do your work when and how you like	1.96	2.05	2.00	1.84
Organization's goal/mission/vision	2.00	1.93	2.00	2.05
Organization's ethical standards	2.00	2.02	2.00	1.99
Level of technology employed at the company	2.08	2.13	2.16	1.97
Opportunity to be creative**	2.09	2.30	2.13	1.88
Relationship with immediate supervisor/boss	2.10	2.16	2.03	2.11
Human diversity (gender, ethnicity)	2.11	2.24	2.02	2.08
Level of challenge in work	2.11	2.24	2.06	2.04
Personal gratification you feel from doing your job**	2.11	2.34	2.08	1.95
Job security	2.21	2.21	2.20	2.22
Respect by upper management	2.25	2.21	2.21	2.31
Ability to balance work and the rest of your life**	2.26	2.41	2.33	2.07
Proximity of work to your home	2.29	2.22	2.41	2.23
Work environment or work culture	2.29	2.39	2.25	2.24
Fringe benefits	2.51	2.54	2.37	2.59
Effectiveness of organizational leadership	2.58	2.72	2.51	2.52
Salary	2.71	2.85	2.59	2.70
Potential for career/professional advancement**	2.75	2.54	2.75	2.94
Amount of on-the-job stress	2.84	2.93	2.88	2.73
Support for continuing education/in-service programs	2.86	2.97	2.77	2.85
Accessibility/proximity of childcare services	2.99	2.97	3.04	2.96

Table 3

* Measured on a 5-point scale where 1 = Very Satisfied and 5 = Very Dissatisfied.

**The differences among the categories for these facets are statistically significant ($p=0.003$, 0.005 , 0.024 , and 0.032 , in order from top to bottom).

- Potential for career/professional advancement (youngest age group most satisfied).

Consistent with the stereotypes of Gen Y, the younger employees were more dissatisfied than the older groups on three of the four facets.

Discussion

The main conclusion from the study is that there is little support for the stereotype of the spoiled, high-maintenance Gen Y employee in the graphic arts industries. In terms of overall job satisfaction, younger employees were not statistically different in their attitudes when compared to older employees. There were significant differences found on specific job facet measures, but only on four of the 23 facets measured. The age differences found on job facets were consistent with prior research in that they deal with meaningful work and work/life balance. However, where age effects were found, the absolute differences between the highest and lowest groups were less than 0.5 scale-points. Furthermore, there were more similarities than differences by age on attitudes towards level of challenge of the work, flexibility to do the work, relationships with co-workers, satisfaction with their immediate supervisors, and salary. These results lend credence to the critics who claim that the generational differences in work attitudes among workers have been exaggerated.

The implication from these findings is that workers, regardless of age, should be treated in the same way. If one age group wants flexibility in work hours, it is very likely that employees of all ages would enjoy a similar benefit. As the leaders of printing, publishing, and other graphic arts industries develop strategies for recruiting and keeping the younger employees, these strategies will most likely be attractive to older employees as well.

The limitations of this research come primarily from the nature of the sampled population. Since the survey was restricted to the alumni of one university, it may not be representative of all employees in the graphic arts industries. In addition, the sampled alumni were those who maintain contact with their alma mater and may represent those who are the most successful. Those that have left the industry and not remained in contact with RIT were not part of the sampling frame. Therefore, the absolute levels of job satisfaction are likely to be overstated in this research.

References

- Armour, S. (2005, 6 November). Generation Y: They've arrived at work with a new attitude. *USA Today*. Available from http://www.usatoday.com/money/workplace/2005-11-06-gen-y_x.htm
- CareerBuilder.com. (2007, 24 October). New CareerBuilder.com study reveals significant gap between Generation Y workers and co-workers. Available from http://www.careerbuilder.com/share/aboutus/pressreleasesdetail.aspx?id=pr403&sd=10%2f24%2f2007&ed=12%2f31%2f2007&siteid=cbpr&sc_cmp1=cb_pr403&cbRecursionCnt=1&csid=fc0e5a7698994246883acd016ab4c292-254490559-KH-5
- Davis, G. (2004). Job satisfaction survey among employees in small businesses. *Journal of Small Business and Enterprise Development*, 11(4), 495.
- Gerdes, L. (2007, 17 April). A good time to hunker down. *BusinessWeek*. Available from http://www.businessweek.com/careers/content/apr2007/ca20070417_437652.htm
- Glass, A. (2007). Understanding generational differences for competitive success. *Industrial and Commercial Training*, 39(2), 98-103.
- Hira, N.A. (2007, 15 May). Attracting the twentysomething worker. *Fortune*. Available from http://money.cnn.com/magazines/fortune/fortune_archive/2007/05/28/100033934
- Jayson, S. (2006, 6 December). Gen Y makes a mark and their imprint is entrepreneurship. *USA Today*. Available from http://www.usatoday.com/news/nation/2006-12-06-gen-next-entrepreneurs_x.htm
- Jayson, S. (2007, 9 January). Generation Y's goal? Wealth and fame. *USA Today*. Available from http://www.usatoday.com/news/nation/2007-01-09-gen-y-cover_x.htm
- Jepsen, D.A., & Sheu, H-B. (2003). General job satisfaction from a developmental perspective: Exploring choice-job matches at two career stages. *The Career Development Quarterly*, 52(2), 162-179.

Macky, K., Forsyth, S., & Boxall, P. (2008). Generational differences at work: The impact of cohort on work attitudes and outcomes. Manuscript submitted for publication.

Martin, C.A. (2005). From high maintenance to high productivity: What managers need to know about Generation Y. *Industrial and Commercial Training*, 37(1), 39-44.

Oshagbemi, T. (2003). Personal correlates of job satisfaction: Empirical evidence from UK universities. *International Journal of Social Economics*, 30(12), 1210-1232.

Read, E. (2007, November). People management: Myth-busting Gen Y. *New Zealand Management*, 63.

Rowh, M. (2007 January). Managing younger workers. *OfficeSOLUTIONS*, 24(1), 29-31.

Safer, M. (2007, 11 November). The "millennials" are coming. *CBS News*. Available from <http://www.cbsnews.com/stories/2007/11/08/60minutes/main3475200.shtml>

[com/stories/2007/11/08/60minutes/main3475200.shtml](http://www.cbsnews.com/stories/2007/11/08/60minutes/main3475200.shtml)

Spiro, C. (2006). Generation Y in the workplace. *Defense AT&L*, November-December 2006.

Trunk, P. (2007, 5 July). What Gen Y really wants. *Time*. Available from <http://www.time.com/magazine/article/0,9171,1640395,00.html>

Westerman, J.W., & Yamamura, J.H. (2007). Generational preferences for work environment fit: Effects on employee outcomes. *Career Development International*, 12(2), 150-161.

This is a refereed paper



Manuscript Guidelines

Eligibility for Publication

Members of the International Graphic Arts Education Association, or students of IGAEA members, may publish in the *Visual Communications Journal*.

Audience

Write articles for educators, students, graduates, industry representatives, and others interested in graphic arts, graphic communications, graphic design, commercial art, communications technology, visual communications, printing, photography, journalism, desktop publishing, drafting, telecommunications, or multi-media. Present implications for the audience in the article.

Types of Articles

The *Visual Communications Journal* accepts four levels of articles for publication:

1. Edited articles are accepted or rejected by the editor. The editor makes changes to the article as necessary to improve readability and/or grammar. These articles are not submitted to a panel of jurors. The decision of the editor is final.
2. Juried articles are submitted to the editor and are distributed to jurors for acceptance/rejection. Juried articles are typically reviews of the literature, state-of-the-art technical articles, and other nonempirical papers. Jurors make comments to the author, and the author makes required changes. The decision of the jurors is final.
3. Refereed articles are submitted to the editor and are distributed to jurors for acceptance/rejection. Refereed articles are original empirical research. Jurors make comments to the author and the author makes required changes. The decision of the jurors is final.

4. Student articles are submitted by IGAEA members and are accepted/rejected by the editor. These articles are not submitted to a panel of jurors. The editor's decision is final.

Submittal of Manuscripts

All manuscripts must be received by the editor no later than December 15th to be considered for the spring *Journal* or by June 15th to be considered for the fall *Journal*. Include digital copies of all text and figures. Prepare text and artwork according to the instructions given in these guidelines. Be sure to include your name, mailing address, e-mail address, and daytime phone number with your materials. E-mail all materials to the editor (address shown below).

Acceptance and Publication

If your article is accepted for publication, you will be notified by e-mail. The *Visual Communications Journal* is published and distributed twice a year, in the spring and in the fall. Hard copies are mailed to IGAEA members. A PDF version of the *Journal* is published online at www.igaea.org.

Notice

Articles submitted to the *Journal* cannot be submitted to other publications while under review. Articles published in other copyrighted publications may not be submitted to the *Journal*, and articles published by the *Journal* may not be published in other publications without written permission of the *Journal*.

Submit All Articles and Correspondence to:
jwaite@uh.edu
or check www.igaea.org for contact information for the IGAEA First Vice-President.

See following page for style guidelines

Manuscript Form and Style

- Prepare manuscripts according to the APA style, including the reference list.
- List your name and address on the first page only. Article text should begin on the second page.
- Provide a short biography for yourself that can be used if the article is accepted for publication.
- All articles must be submitted in electronic form on a CD-ROM or as an email attachment.
- Submit a Microsoft Word document, maximum of 10 pages (excluding figures, tables, illustrations, and photos). Do not submit documents created in page-layout programs.
- Word documents must have been proofread and be correct.
- Call out the approximate location of all tables and figures in the text. Use the default style “Normal” on these callouts. The call-outs will be removed by the designer.
- Use the default Word styles only. Our designer has set up the page layout program styles to correspond to those style names.
 - ◆ Heading 1
 - ◆ Heading 2
 - ◆ Heading 3
 - ◆ Normal

Graphics

- Be sure that submitted tables and other artwork are absolutely necessary for the article.
- Write a caption for each graphic, include captions in a list at the end of your Word document.
- Electronic artwork is preferred and should be in PDF or TIFF format.
- Send all artwork files and hard copies of these files with your submission.

Tables

- Set up tables in separate documents, one document for each table.
- Do not attempt to make it “pretty.” Use the default Word style “Normal” for all table text. Do not use any other formatting.
- Do not use hard returns inside the table (“enter” or “return”).
- Get the correct information into the correct cell and leave the formatting to the designer.
- Tables will be formatted by the designer to fit in one column (3.1667" wide) or across two columns (6.5" wide).

Artwork

- Scan photographs at 300 ppi resolution.
- Scan line drawings at 800 ppi resolution.
- Screen captures should be as large as possible.
- Graphics should be sized to fit in either one column or across two columns.
 - ◆ One column is 3.1667" wide, two columns are 6.5" wide.
 - ◆ Graphics may be larger than these dimensions, but must not be smaller.



007301026
International Graphic Arts Education Association
care of
University of Houston Information & Logistics Technology Department
312 Technology Building
Houston, TX 77204-4023

NONPROFIT
ORGANIZATION
U.S. POSTAGE
PAID
HOUSTON
TEXAS
NO. 5910